

Cookin' On Hydrogen

Stove Burner Conversion

David Booth and Walt Pyle

©1993 David Booth and Walt Pyle

Converting conventional stove top burners to run on hydrogen is a simple process. Knowing the proper handling procedures of hydrogen will make your installation safe and efficient.

Theory Before Practice

Hydrogen burns differently than either propane or natural gas. In particular, hydrogen's rate of diffusion and flame velocity are roughly ten times or greater than that of propane or natural gas. Diffusion rate measures how long it takes a gas introduced in one side of a room to be detected on the other side. Flame speed is how fast a flame travels to burn available fuel-air mixture.

Flashback of the flame into the primary mixture of fuel gas and air must be prevented in all burners. This is typically achieved with natural gas and propane by adjusting the fuel velocity so that it is higher than the normal flame velocity. The flame velocity of hydrogen is too high for this technique to be practical. Another flashback control strategy employs burner ports with a minimum quenching diameter which theoretically will not allow the flame to pass back through the port. In practice, however, it is very difficult to make the holes small enough to quench a hydrogen flame. Fortunately, flashback can be minimized by preventing hydrogen from mixing with air before the burner port. Some flashback may still occur creating a loud popping sound but this noise is usually harmless.

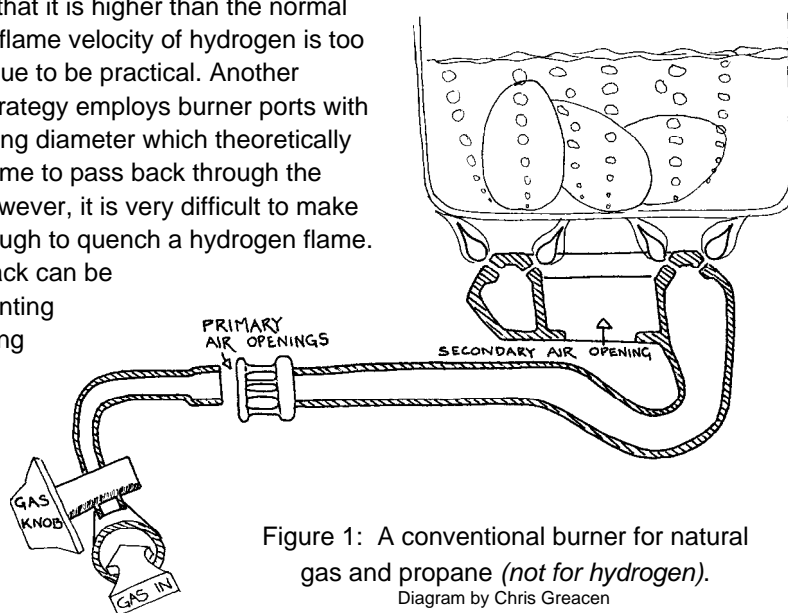

Figure 1: A conventional burner for natural gas and propane (*not for hydrogen*).

Diagram by Chris Greacen

Figure 1 shows the principal parts of a typical range top burner used with conventional gaseous fuels. Usually the fuel streams in through a gas orifice with a delivery pressure between 3-15 inches of water column. Primary air is then drawn in with the gas stream through an air-gas mixer. Secondary air openings to mix in more air may or may not be present. Finally, as the mixture exits through the burner ports, combustion occurs, if a spark ignition source or pilot light is present.

Horse of a Different Color

This burner design will not suffice for hydrogen in an unaltered state. Burners optimized for hydrogen combustion require that undiluted hydrogen be delivered directly to the burner ports without primary or secondary air mixing. So, if we are trying to work with an existing burner in a typical gas appliance, we will have to find a suitable method to seal off any openings that were installed for this purpose. There's no method that will work in all instances. The actual openings we are referring to may be an integral part of a cast iron body. Or the primary air openings may be a modest distance from the burner head in an aluminum delivery tube with an adjustable closure. We used silicon sealant with stainless steel tape and ring clamps in one recent alteration, but this simple Coleman stove conversion hasn't been subjected to long term use as yet.

From Scratch

One might opt to build a simple hydrogen burner and direct fuel delivery apparatus from the ground up, rather than deal with the problem of sealing off a nagging assortment of useless holes. Burners and their attached parts get hot, and transfer heat readily through conduction. Sorry, duct tape and chewing gum won't cut it.

Our first attempt at a simple hydrogen conversion utilized a rudimentary two burner range of cast iron construction. See Figure 2. After we tossed the existing burner assembly, and removed the screwed-on brass orifice, a threaded adaptor was exposed. To this we attached a 1/4 inch NPT straight coupling followed by a short length of black iron pipe

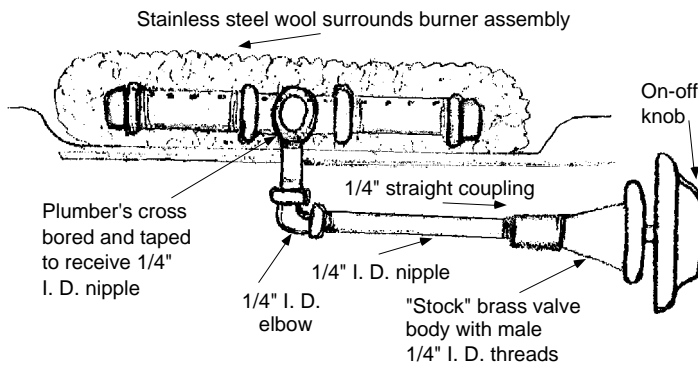

Figure 2: Pure hydrogen is delivered to burner ports without primary or secondary air mixing.
Diagram by David Booth

of the same diameter. Don't use galvanized pipe, because of the fumes that will be released at high temperatures. Then we installed a 90 degree elbow followed by a short vertical nipple of more pipe. Next a 3/8 inch NPT fitting shaped like a cross with four female threaded openings was drilled and tapped to create a fifth hole. See Figure 3. This threaded onto the short vertical nipple, and four slightly longer nipples of equal length extended out radially from the remaining holes. Finally, these terminated in threaded end caps. A drill press is almost essential for drilling a series of very fine holes which line up along the top of the radial burner arms, and through the top of the cross. Ideally, these burner ports would have a 0.057 cm (0.0225 inch) diameter or less, which is the approximate minimum quenching diameter.

The Catalytic Advantage

It has been observed in early experiments that the flame combustion of hydrogen/air mixtures can lead to unacceptable levels of nitrogen oxide (NO_x) pollutant emissions. The primary end product of hydrogen combustion is simply water vapor. However, if the temperature of combustion exceeds a threshold level of about 1315°C (2400°F), a significant amount of oxygen and nitrogen from the air may react and form this unwanted byproduct. This also occurs with natural gas (primarily methane), propane, and other hydrocarbon fuel combustion.

Fortunately, you can use a catalyst to lower the combustion temperature thus preventing the formation of nitrogen oxides. The catalytic material is not used up or altered in any fashion in the process.

There are two catalytic conversion techniques which succeed in producing negligible levels of NO_x emissions.

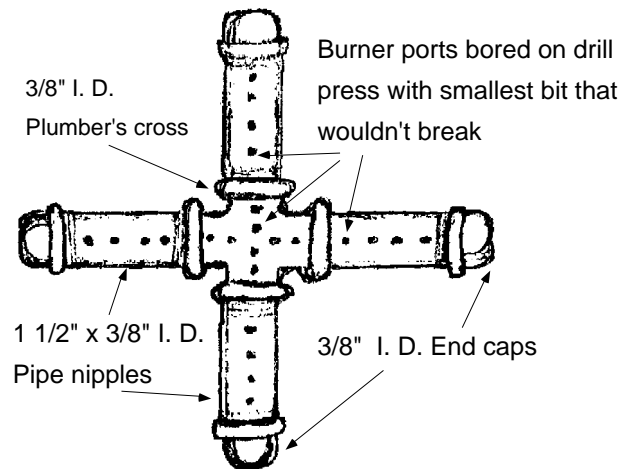

Figure 3: Top view of radial burner made from scratch using black iron pipe fittings.
Diagram by David Booth

The first approach is based on Billings and his associates' work with flame assisted catalytic burners. Their conversions utilized the catalytic properties of stainless steel at elevated temperatures. Later, in another article, we'll describe the conversion of a catalytic space heater which optimizes "flameless" combustion with a small amount of platinum.

Flame Assisted Catalysis

The technique developed by the Billing's research team to reduce NO_x formation relies on controlling two interacting phenomena. First, as has already been described, hydrogen/air mixing is inhibited by blocking off any primary air openings. Second, a stainless steel wire mesh is arranged tightly around the circular burner head or radial burner arms, as shown in Figure 2.

Where does one find stainless steel wool or wire mesh? Look for stainless steel pot scrubbers in a large, thoroughly stocked supermarket in the housewares section.

Getting our NO_x Off

This stainless steel wool blanket around the burner actually serves two complementary functions. It inhibits the mixing of air and hydrogen thus producing a zone immediately surrounding the burner head where the concentration of hydrogen is very high and the concentration of air is very low. The wire mesh should be thick enough so that the flame does not radiate above it or out too far laterally.

Stainless steel also works as an excellent catalyst for hydrogen combustion. If there isn't a sufficient amount of stainless steel mesh, the catalytic capability and ability to

prevent NO_x production could be lost. Hydrogen and oxygen are thus combined on the surface of the catalyst at a lower temperature than would occur without the catalyst. The result of the lowered combustion temperature is that nitrogen oxides are virtually eliminated. The steel wool proceeds to glow bright red even at these temperatures, indicating that the otherwise invisible hydrogen flame is present.

According to Roger Billings in *The Hydrogen World View*, the flame-assisted catalytic technique can lower NO_x emission from hydrogen combustion in range burners, ovens, and space heaters to negligible levels. The resulting data showed NO_x emission levels between 1 and 5 parts per million (ppm) for a catalytic assisted burner. This can be compared with 40 ppm for conventional range burners operated on natural gas and up to 250 ppm for a hydrogen burner without a catalyst. These burner emission levels are all quite low, however, compared to internal combustion engine exhaust gas NO_x production.

More to Come

We need to build a sound understanding, before we can confidently proceed to implement hydrogen for scores of potential uses. If you'd like more information, dig into the references at the end of the article.

In the next issue, we will delve into a technique for transforming the chemical energy stored in hydrogen to available heat energy without the presence of a flame. This form of combustion is possible when hydrogen is oxidized in the presence of certain specific catalysts such as platinum. This is considered "pure" catalytic combustion. Water vapor is the only byproduct along with heat, so no venting of the appliance may be necessary (if means to prevent oxygen depletion for the room air is assured). At this time, most city and county building codes require an exhaust flu for stoves running all gaseous fuels, and we recommend that the room where the stove is being used be vented to the outdoors.

We're in the process of putting together a system that will convert renewable solar electricity into the storable chemical energy of hydrogen through the process of electrolysis. The process is still underway but we will offer detailed accounts of our endeavors in forthcoming issues.

Spreading the Invisible Flame

There may well be a wealth of undiscovered and untapped hands-on information available from other hydrogen enthusiasts out there scattered through the countryside. If you are among the other backyard tinkerers and hydrogen pioneers who are putting theory into practice, let us hear from you. The time has come to

spread the word about hydrogen's unique advantages. It is clearly the hands-down winner among the possible candidates of alternative fuels for the future in our environmentally beleaguered world.

A Note on Safety

Remember that storing pure hydrogen can be regarded as a relatively safe procedure, but storing hydrogen /air or hydrogen/oxygen mixtures is foolhardy and strictly inadvisable.

Much of the research that we referred to in this article was performed by Roger Billings, N. R. Baker, and their associates of the now defunct Billings Energy Corporation. This pioneering work was done mostly in the 1970s. An early research endeavor involved conversion of all the gas appliances on a Winnebago recreational vehicle from propane to hydrogen operation. To demonstrate hydrogen's practicality even further, five natural gas appliances were converted to hydrogen. This multi-phased project in Provo, Utah was called the Hydrogen Homestead. Included among the appliances converted for this home were an oven, a range, a barbeque, a fireplace log burner, and the booster heater for the home's heat pump system.

Access

Authors: David Booth, Alternative Energy Engineering, POB 391, Miranda, CA 95553 • 707-923-4336

Walt Pyle, WA6DUR, Richmond, CA • 510-237-7877

Further Reading

1. *Oxides of Nitrogen Control Techniques for Appliance Conversion to Hydrogen Fuel*, technical paper #74003, by N.R. Baker is available from the International Academy of Science, 26900 Pink Hill Road, Independence, MO 64057 • 816 229-3800.
2. *Hydrogen Homestead*, technical paper #78005, by Roger Billings is available from the International Academy of Science.
3. *Fuel from Water* by Michael Peavey is available from Alternative Energy Engineering for \$16 and Real Goods.
4. *The Hydrogen World View* by Roger Billings is available from the International Academy of Science.

